

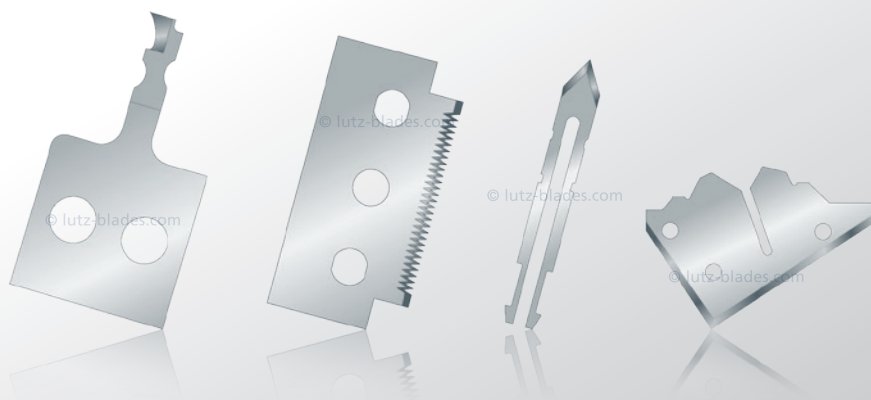

PLACE YOUR TRUST IN PRECISION AND EFFICIENCY – MEDICAL BLADES FROM LUTZ



CUSTOM BLADES

FILM AND FOIL

CHEMICAL FIBRES AND FIBREGLASS

MEDICAL

FOOD

DIY

AUTOMOTIVE

TEXTILES

PRECISION. SHARPNESS. SUCCESS.
exactly

Reasons why you need LUTZ BLADES:



PRECISION.

Our maxim is precision – and it is this principle that accompanies every stage from the initial idea to the finished product. Right through to the ideal solution for your specific cutting application to ensure your requirements are met. Throughout every design and development stage and every production step – blade after blade after blade.



SHARPNESS.

We have been making blades and cutters since 1922. From razor-sharp, for extremely fine cutting jobs to extremely robust for impact and pressure cutting actions. Together with the customer, we define all the relevant parameters to ensure your individual requirements are met – to provide greater sharpness and better service lifetimes.

SUCCESS.

exactly

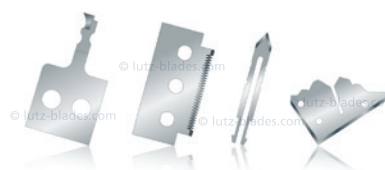

Your competitive advantage when you use blades from LUTZ in medical technology is the sum of all our efforts and the details we guarantee you. We are pleased to show you those details because your success is our objective – from the first to the millionth blade.

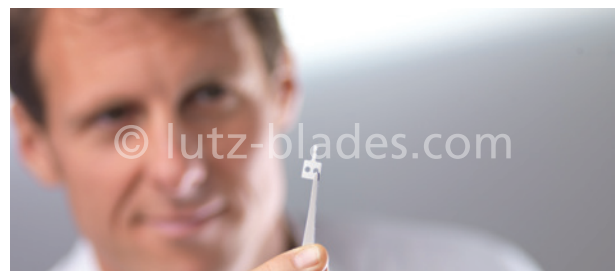

LUTZ MEDICAL BLADES

Thanks to their precision, high-grade craftsmanship and outstanding service lifetimes, LUTZ blades are in use in numerous medical contexts with market leaders.

Typical fields are surgery, pathology and in the manufacture of PVC catheters and stents.

Our production range includes, amongst others: ophthalmology blades, microdissection cutters, trocars for laparoscopy, punched blades for biopsies, precision and special-purpose blades for histology and dermatology, blood lancets, blades for precision incisions in PVC tubes, stents and powder inhalers.













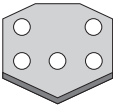

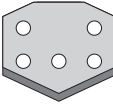





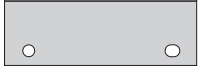

CUSTOM BLADES | FILM AND FOIL | CHEMICAL FIBRES AND FIBREGLASS | MEDICAL | FOOD | DIY | AUTOMOTIVE | TEXTILES

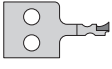
LUTZ allows access to all its website content for viewing purposes. Copying and reproducing content (copy, images etc.) for anything more than transient use is not permitted. This content may not be modified or used on other websites or networked computers without prior written approval by LUTZ GmbH & Co. KG.

Copyright: © COPYRIGHT LUTZ GmbH & Co. KG, Solingen, Germany. All rights reserved. Copy, photos, graphics, technical drawings, layouts and other information used in all our publications and their arrangements on our LUTZ website are subject to copyright and other proprietary rights.

Proprietary rights: The owner of the brandnames used by LUTZ is LUTZ GmbH & Co. KG, Solingen, Germany (unless otherwise stated). Third Parties are explicitly prohibited from using any of the brandnames, logos or marks of any kind found there. This applies in particular to the internationally registered trademark symbols LUTZ, which consist of the letters LUTZ in a stylized font, all violations against trademark law regarding its trademarks.

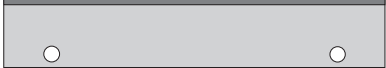
E & OE. Brandnames marked with an asterisk (*) are not owned by LUTZ GmbH & Co. KG. Subject to our general terms & conditions on the Internet at www.lutz-blades.com.

Ref.	Length (mm)	Width (mm)	Thickn. (mm)	Ref.	Length (mm)	Width (mm)	Thickn. (mm)	Ref.	Length (mm)	Width (mm)	Thickn. (mm)
 0010.0400 0014.0500	23.0	21.0	0.40 0.50	 0330.0380	50.0	18.8	0.38	 0150.0200	66.0	22.0	0.20
 0012.0500 0013.0200	23.8	21.0	0.50 0.20	 0160.0250	4.0	5.0	0.25	 4180.0250	78.6	18.4	0.25
 0023.0500	14.0	12.0	0.50	 0916.0250	11.4	8.0	0.25	 4183.0250	15.0	12.5	0.25
 0071.0300	27.0	7.5	0.30	 0331.0380	90.0	18.8	0.38	 4181.0250	52.4	18.4	0.25
 0072.0200	10.0	4.5	0.20	 1600.0500	16.9	9.0	0.50	 4182.0250	26.2	18.4	0.25
 0070.0630	45.6	12.8	0.63	 3300.0380	25.4	8.7	0.38	 4184.0400	8.0	7.0	0.40
 4120.0250	33.0	4.1	0.25	 4100.0380	106.4	18.8	0.38				
				 4110.0380	111.2	32.6	0.38				

AND THIS IS HOW YOU CAN BENEFIT FROM LUTZ BLADES AND LUTZ CAPABILITIES

- » Accurate cutting action and consistently excellent cutting quality
- » High cutting efficiency
- » Initial samples after only a few days and without tooling costs
- » Traceable thanks to identification marks on each individual blade













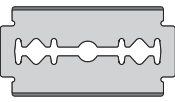
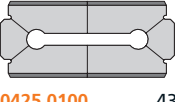
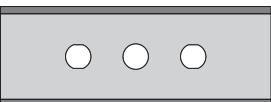



CUSTOM BLADES | FILM AND FOIL | CHEMICAL FIBRES AND FIBREGLASS | MEDICAL | FOOD | DIY | AUTOMOTIVE | TEXTILES









LUTZ allows access to all its website content for viewing purposes. Copying and reproducing content (copy, images etc.) for anything more than transient use is not permitted. This content may not be modified or used on other websites or networked computers without prior written approval by LUTZ GmbH & Co. KG.

Copyright: © COPYRIGHT LUTZ GmbH & Co. KG, Solingen, Germany. All rights reserved. Copy, photos, graphics, technical drawings, layouts and other information used in all our publications and their arrangements on our LUTZ website are subject to copyright and other proprietary rights.

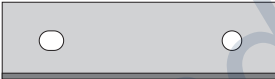
Proprietary rights: The owner of the brandnames used by LUTZ is LUTZ GmbH & Co. KG, Solingen, Germany (unless otherwise stated). Third Parties are explicitly prohibited from using any of the brandnames, logos or marks of any kind found there. This applies in particular to the internationally registered trademark symbols LUTZ, which consist of the letters LUTZ in a stylized font, all violations against trademark law regarding its trademarks.

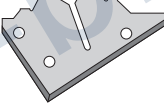
E & OE. Brandnames marked with an asterisk (*) are not owned by LUTZ GmbH & Co. KG. Subject to our general terms & conditions on the Internet at www.lutz-blades.com.

Ref.	Length (mm)	Width (mm)	Thickn. (mm)
	43.0	22.2	0.10
0420.0100			
	43.5	19.0	0.10
0425.0100			
	60.0	22.2	0.10
0600.0100			
			0.13
0600.0130			
			0.15
0600.0150			
			0.20
0600.0200			
			0.30
0600.0300			
	80.0	8.0	0.30
6032.0300			
	43.0	22.2	0.06
0410.0060			
			0.08
0410.0080			
			0.10
0410.0100			
			0.13
0410.0130			
			0.15
0410.0150			
			0.20
0410.0200			
			0.30
0410.0300			
			0.40
0410.0400			
			0.65
0410.0650			

Ref.	Length (mm)	Width (mm)	Thickn. (mm)
	69.7	17.7	0.50
2016.0500			
	81.0	18.8	0.40
4240.0400			
	80.0	22.0	0.30
4242.0300			
		22.2	0.30
4244.0300			
	32.0	32.0	0.70
4440.0700			
	157.0	18.3	0.25
6430.0250			
	209.0	17.7	0.50
2001.0500			
	217.0	19.1	0.65
2003.0650			

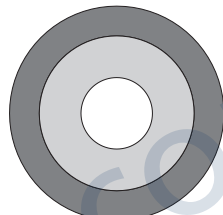
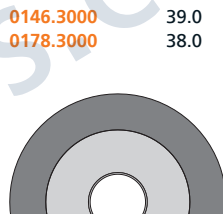
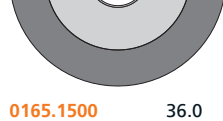
Ref.	ø OD (mm)	ø ID (mm)	Thickn. (mm)
	39.0	10.0	3.00
0146.3000			
	38.0	10.0	3.00
0178.3000			
	36.0	12.0	1.50
0165.1500			

FEATURES OF LUTZ AND ITS PRODUCTS

- » Processes comply with EN ISO 13485:2007 and EN ISO 9001:2008
- » Rapid prototyping
- » Automatic measurement and testing of all critical parameters
- » Certified suitable for cleanroom use
- » Comprehensive materials portfolio from rust-resistant to ceramic
- » Hard and frictionless coatings designed to match the specific application











CUSTOM BLADES | FILM AND FOIL | CHEMICAL FIBRES AND FIBREGLASS | MEDICAL | FOOD | DIY | AUTOMOTIVE | TEXTILES

LUTZ allows access to all its website content for viewing purposes. Copying and reproducing content (copy, images etc.) for anything more than transient use is not permitted. This content may not be modified or used on other websites or networked computers without prior written approval by LUTZ GmbH & Co. KG.

Copyright: © COPYRIGHT LUTZ GmbH & Co. KG, Solingen, Germany. All rights reserved. Copy, photos, graphics, technical drawings, layouts and other information used in all our publications and their arrangements on our LUTZ website are subject to copyright and other proprietary rights.

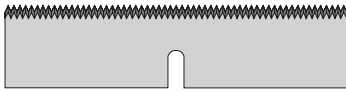
Proprietary rights: The owner of the brandnames used by LUTZ is LUTZ GmbH & Co. KG, Solingen, Germany (unless otherwise stated). Third Parties are explicitly prohibited from using any of the brandnames, logos or marks of any kind found there. This applies in particular to the internationally registered trademarks of LUTZ, which are subject to the provisions of trademark law regarding its trademarks.

E & OE. Brandnames marked with an asterisk (*) are not owned by LUTZ GmbH & Co. KG. Subject to our general terms & conditions on the Internet at www.lutz-blades.com.

Ref.	Length (mm)	Width (mm)	Thickn. (mm)	Ref.	Length (mm)	Width (mm)	Thickn. (mm)	Ref.	Length (mm)	Width (mm)	Thickn. (mm)
 6030.0254	38.0	8.0	0.25	 5601.0150	15.6	7.9	0.15	 4711.0370	111.1	32.5	0.37
 7160.0500	25.4	8.0	0.50	 5602.0150	15.6	7.9	0.15	 8948.0500	126.0	50.0	0.50
 8933.0500	27.3	8.0	0.50	 5600.0150	15.6	7.9	0.15	 8115.0510	108.0	25.4	0.51
 2100.0400	16.3	18.7	0.40	 6036.0254	38.0	8.0	0.25	 0840.0300	99.0	20.0	0.30
 6390.0500	36.0	5.5	0.50	 7600.0390	23.3	5.2	0.39	 9704.0300	43.0	21.5	0.30
 7250.0650	59.4	11.1	0.65	 6396.0500	32.9	5.8	0.50	 7153.0152	endless	18.8	0.15
 6415.0630	4.3	11.2	0.63	 4342.0460	6.3	9.9	0.46				
 0047.0500	18.0	4.4	0.50	 0026.0500	41.0	5.6	0.50				
 0303.0300	40.0	19.5	0.30								

CHOICE OF MATERIAL

Our range of products covers blades of between 0.06 and 3.0 mm in thickness and with final hardness ratings of 40 - 85 HRc.

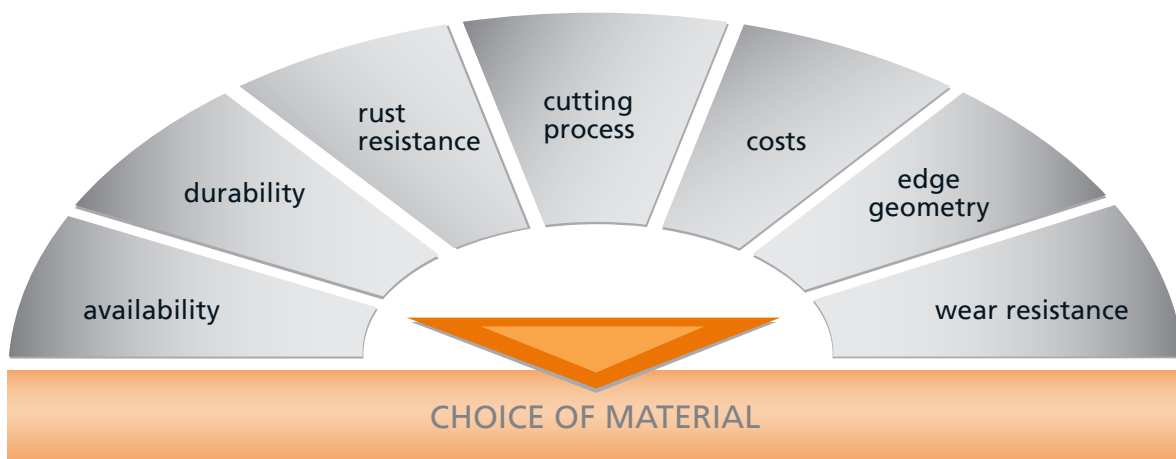

- Our range of materials includes:
- » Carbon steels
 - » Stainless and rust-resistant steels
 - » Highspeed steels (HSS)
 - » Tool steels
 - » Tungsten carbides
 - » Ceramics

LUTZ allows access to all its website content for viewing purposes. Copying and reproducing content (copy, images etc.) for anything more than transient use is not permitted. This content may not be modified or used on other websites or networked computers without prior written approval by LUTZ GmbH & Co. KG.

Copyright: © COPYRIGHT LUTZ GmbH & Co. KG, Solingen, Germany. All rights reserved. Copy, photos, graphics, technical drawings, layouts and other information used in all our publications and their arrangements on our LUTZ website are subject to copyright and other proprietary rights.

Proprietary rights: The owner of the brandnames used by LUTZ is LUTZ GmbH & Co. KG, Solingen, Germany (unless otherwise stated). Third Parties are explicitly prohibited from using any of the brandnames, logos or marks of any kind found there. This applies in particular to the internationally registered trademarks of LUTZ, which include, without limitation, the graphic symbols LUTZ and exactly, all violations against trademark law regarding its trademarks.

E & OE. Brandnames marked with an asterisk (*) are not owned by LUTZ GmbH & Co. KG. Subject to our general terms & conditions on the Internet at www.lutz-blades.com.

CUTTING EDGE SHAPES

For the definition of edge type and bevel configuration see the following matrix:



LUTZ allows access to all its website content for viewing purposes. Copying and reproducing content (copy, images etc.) for anything more than transient use is not permitted. This content may not be modified or used on other websites or networked computers without prior written approval by LUTZ GmbH & Co. KG.

Copyright: © COPYRIGHT LUTZ GmbH & Co. KG, Solingen, Germany. All rights reserved. Copy, photos, graphics, technical drawings, layouts and other information used in all our publications and their arrangements on our LUTZ website are subject to copyright and other proprietary rights.

Proprietary rights: The owner of the brandnames used by LUTZ is LUTZ GmbH & Co. KG, Solingen, Germany (unless otherwise stated). Third Parties are explicitly prohibited from using any of the brandnames, logos or marks of any kind found there. This applies in particular to the internationally registered trademarks, symbols, LUTZ logos, which are subject to trademark law regarding its trademarks.

E & OE. Brandnames marked with an asterisk (*) are not owned by LUTZ GmbH & Co. KG. Subject to our general terms & conditions on the Internet at www.lutz-blades.com.

		single edged	double edged	convex	concave
one sided					
		a	g	m	t
		b	h	n	u
two sided		c	i	o	v
		d	j	p	w
		e	k	r	x
		f	l	s	y

COATINGS

Sharpness
Quality of the cut

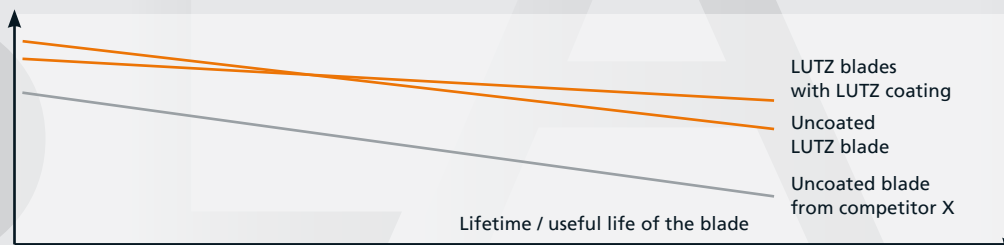

The LUTZ coatings range includes the following choices:

TiN

Standard hard coating with tough resistance to wear with a relatively high coefficient of friction (compared with steel as a reference material: 0.4 to 0.7), usually gold coloured, safe use at up to approx. 300 °C.

TiC

Has lower resistance to wear than TiN and a considerably lower coefficient of friction (compared with steel as a reference material: 0.3 to 0.5), usually charcoal grey.

TiCN

Takes a position between the high wear resistance of TiN and the low coefficient of friction of TiC, relative position between TiN and TiC depending on C and N content, usually charcoal grey.

TiAlN

Has greater resistance to oxidation than TiN with a comparable coefficient of friction, usually charcoal grey.

ZrN

With wear resistance similar to TiN, but with a more dense morphology than TiN and, as a result, more resistant to pitting under comparable load, usually steel colour.

CrN

Lower wear resistance than TiN. The advantage of CrN is it has a lower inherent tension than TiN. As a result, can be used for applications with high bending loads.

DLC

Has a high wear resistance and a low coefficient of friction (approx. 0.4 compared with steel as a reference); sensitive to impacts and high temperatures (between 100° and 300 °C depending on structure).

Teflon® (PTFE)

Non-stick coating Teflon® (PTFE), very low static friction allows a smooth cut, therefore a popular coating for medical devices. Because of the low surface tension almost no contamination from the cut goods. Acid and base-resistant, not suitable in combination with Na (sodium). Temperature resistant up to 250°C (480°F). Medium wear resistance.

Coloured lacquer

Applied to entire surface, acts as an aid to sorting different material thicknesses and as anticorrosion protection.

Bluing and blackening

Applied to entire surface, some anticorrosion protection and thickness protection, also aids differentiation.

LUTZ allows access to all its website content for viewing purposes. Copying and reproducing content (copy, images etc.) for anything more than transient use is not permitted. This content may not be modified or used on other websites or networked computers without prior written approval by LUTZ GmbH & Co. KG.

Copyright: © COPYRIGHT LUTZ GmbH & Co. KG, Solingen, Germany. All rights reserved. Copy, photos, graphics, technical drawings, layouts and other information used in all our publications and their arrangements on our LUTZ website are subject to copyright and other proprietary rights.

Proprietary rights: The owner of the brandnames used by LUTZ is LUTZ GmbH & Co. KG, Solingen, Germany (unless otherwise stated). Third Parties are explicitly prohibited from using any of the brandnames, logos or marks of any kind found there. This applies in particular to the internationally registered trademark symbols LUTZ, exactly, which consist of the letters LUTZ, exactly, in all variations against trademark law regarding its trademarks.

E & OE. Brandnames marked with an asterisk (*) are not owned by LUTZ GmbH & Co. KG. Subject to our general terms & conditions on the Internet at www.lutz-blades.com.